

**PHILIPS
LUMEC**

Roadway

StreetView

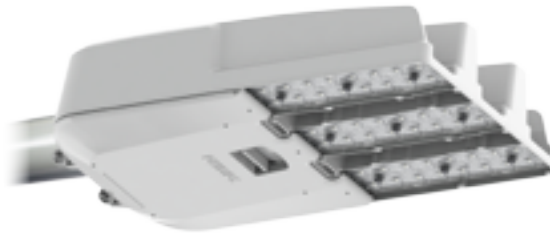

Project: _____
 Location: _____
 Cat.No: _____
 Type: _____
 Lamps: _____ Qty: _____
 Notes: _____

The Philips Lumece StreetView LED luminaire is designed for many applications that require medium intensity lighting. Powered by the Philips LEDgine platform and featuring innovative thermal management design, this LED luminaire has two major assets: exceptional performance and unbeatable value.

Ordering guide

example: SVM-90W48LED4K-G2-LE3-UNIV-DMG-RC-HS-GY3

Luminaire	LED Module	Optical System	Voltage	Driver and Dimming	Twist-Lock Receptacle	Surge Protection	Luminaire Accessories	Finish
SVM					RC			GY3
SVM StreetView Medium	16W16LED4K-G2 ⁴ or 22W16LED4K-G2 ⁴ or 24W16LED4K-G2 ⁴ or 30W16LED4K-G2 ⁴ or 32W32LED4K-G2 or 48W32LED4K-G2 or 60W32LED4K-G2 or 48W48LED4K-G2 or 72W48LED4K-G2 or 90W48LED4K-G2 or 140W48LED4K-G2 ^{2,4}	LE2 Type II LE3 Type III LE5 Type V	UNIV 120-277VAC: 16 LED 32 LED 48 LED 140W 48 LED HVU 347-480VAC: 32 LED 48 LED	<i>Standard:</i> DMG ^{1,5} Dimmable driver 0-10V <i>Optional:</i> (not available for 140W48LED) AMPD ^{2,4,5} Amplight Dimming Dynadimmer Economy Profile CDMGE25 ^{2,4,5} CDMGE50 ^{2,4,5} CDMGE75 ^{2,4,5} Median Profile CDMGM25 ^{2,4,5} CDMGM50 ^{2,4,5} CDMGM75 ^{2,4,5} Safety Profile CDMGS25 ^{2,4,5} CDMGS50 ^{2,4,5} CDMGS75 ^{2,4,5} DALI ^{2,4,5} Digitally Addressable Lighting Interface DMG-AST ^{*2,4} Adjustable Startup Time DMG-CLO ^{*2,4,5} Constant Light Output DMG-OTL ^{*2,4} Over The Life <i>*Includes 0-10v dimming</i>	<i>Standard:</i> RC ^{1,3} Receptacle for twist-lock photocell or shorting cap	<i>Optional:</i> SP2 ⁵ 20kV / 20kA Surge Protector	HS House side shield, 1 per 16 LED light engine PH8 ^{3,4} Twist-lock Photoelectric Cell, UNIV (120-277VAC) PH8/347 ³ (not available for 140W48LED) Twist-lock Photoelectric Cell, HVU (347VAC) PH8/480 ³ (not available for 140W48LED) Twist-lock Photoelectric Cell, HVU (480VAC) PH8XL ^{3,4} Twist-lock Photoelectric Cell, extended life, UNIV (120-277VAC) PH9 ³ Shorting cap SPC ^{3,7} Starsense Photo-cell Control	GY3 Grey finish

- Please note these integrated features come standard with StreetView luminaires.
- Denotes programmable driver option. Not available with HVU (347-480volt).
Not available with 1050 mA version (140W48LED).
- Use of photoelectric cell or shorting cap is required to ensure proper illumination.
- Not available with HVU (347-480volt).
- Dimming choices: Select either DMG or AMPD or one of the CDMG options or DALI.
- When SP2 option is selected you will get SP2 instead of standard SP1.
- Please note that more hardware as well as software are required. Please contact the quotations department for help with putting together the entire control system.

SVM StreetView

LED Cobra Head: 16, 32, and 48 LED

LED wattage and lumen values

LED CRI = 70, CCT = 4000K nominal (3985K +/- 275K or 3710K to 4260K), System (LED + driver) rated life = 100,000 hrs¹

LED Module	Typical delivered lumens	Typical system wattage (W) ²	LED current (mA)	Typical System Current (A) @						Luminaire Efficacy Rating (Lm/W)	BUG rating
				120V	208V	240V	277V	347V	480V		
16W16LED4K-G2-LE2	2164	19	350	0.160	0.100	0.090	0.082			113	B1-U0-G1
16W16LED4K-G2-LE3	2192	19	350	0.160	0.100	0.090	0.082			115	B1-U0-G1
16W16LED4K-G2-LE5	2299	19	350	0.160	0.100	0.090	0.082			123	B2-U0-G0
22W16LED4K-G2-LE2	2822	26	470	0.210	0.125	0.115	0.105			109	B1-U0-G1
22W16LED4K-G2-LE3	2860	26	470	0.210	0.125	0.115	0.105			111	B1-U0-G1
22W16LED4K-G2-LE5	2999	26	470	0.210	0.125	0.115	0.105			116	B2-U0-G1
24W16LED4K-G2-LE2	2965	27	530	0.225	0.135	0.120	0.110			109	B1-U0-G1
24W16LED4K-G2-LE3	3004	27	530	0.225	0.135	0.120	0.110			110	B1-U0-G1
24W16LED4K-G2-LE5	3150	27	530	0.225	0.135	0.120	0.110			115	B2-U0-G1
30W16LED4K-G2-LE2	3792	36	700	0.290	0.175	0.150	0.135			105	B1-U0-G1
30W16LED4K-G2-LE3	3842	36	700	0.290	0.175	0.150	0.135			106	B1-U0-G1
30W16LED4K-G2-LE5	4029	36	700	0.290	0.175	0.150	0.135			112	B3-U0-G1
32W32LED4K-G2-LE2	4085	34	350	0.300	0.185	0.165	0.155	0.105	0.090	118	B1-U0-G1
32W32LED4K-G2-LE3	4139	35	350	0.300	0.185	0.165	0.155	0.105	0.090	120	B1-U0-G1
32W32LED4K-G2-LE5	4341	35	350	0.300	0.185	0.165	0.155	0.105	0.090	126	B3-U0-G1
48W32LED4K-G2-LE2	6132	53	530	0.450	0.270	0.240	0.215	0.160	0.130	116	B2-U0-G1
48W32LED4K-G2-LE3	6214	53	530	0.450	0.270	0.240	0.215	0.160	0.130	117	B2-U0-G1
48W32LED4K-G2-LE5	6515	53	530	0.450	0.270	0.240	0.215	0.160	0.130	123	B3-U0-G1
60W32LED4K-G2-LE2	7752	71	700	0.595	0.340	0.295	0.265	0.210	0.160	109	B2-U0-G2
60W32LED4K-G2-LE3	7855	71	700	0.595	0.340	0.295	0.265	0.210	0.160	110	B2-U0-G2
60W32LED4K-G2-LE5	8237	71	700	0.595	0.340	0.295	0.265	0.210	0.160	116	B3-U0-G1
48W48LED4K-G2-LE2	6341	54	350	0.440	0.260	0.250	0.230	0.160	0.130	117	B2-U0-G1
48W48LED4K-G2-LE3	6426	54	350	0.440	0.260	0.250	0.230	0.160	0.130	118	B2-U0-G2
48W48LED4K-G2-LE5	6734	54	350	0.440	0.260	0.250	0.230	0.160	0.130	124	B3-U0-G1
72W48LED4K-G2-LE2	8985	79	530	0.660	0.390	0.350	0.310	0.225	0.170	114	B2-U0-G2
72W48LED4K-G2-LE3	9105	79	530	0.660	0.390	0.350	0.310	0.225	0.170	116	B2-U0-G2
72W48LED4K-G2-LE5	9542	79	530	0.660	0.390	0.350	0.310	0.225	0.170	121	B3-U0-G2
90W48LED4K-G2-LE2	11475	105	700	0.890	0.515	0.455	0.390	0.305	0.225	109	B2-U0-G2
90W48LED4K-G2-LE3	11628	105	700	0.890	0.515	0.455	0.390	0.305	0.225	111	B2-U0-G2
90W48LED4K-G2-LE5	12186	105	700	0.890	0.515	0.455	0.390	0.305	0.225	116	B4-U0-G2
140W48LED4K-G2-LE2	15790	160	1050	1.330	0.760	0.665	0.575			99	B3-U0-G3
140W48LED4K-G2-LE3	16010	161	1050	1.330	0.760	0.665	0.575			99	B3-U0-G3
140W48LED4K-G2-LE5	17248	162	1050	1.330	0.760	0.665	0.575			106	B4-U0-G2

SVM StreetView

LED Cobra Head: 16, 32, and 48 LED

Dimensions

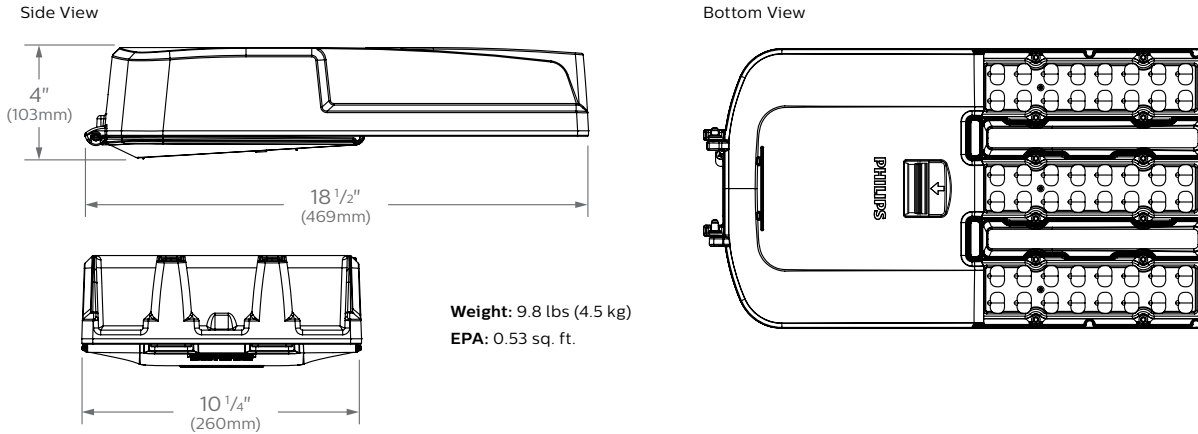

Predicted Lumen Depreciation Data

Predicted performance derived from LED manufacturer's data and engineering design estimates, based on IESNA LM-80 methodology. Actual experience may vary due to field application conditions. L70 is the predicted time when LED performance depreciates to 70% of initial lumen output. Calculated per IESNA TM21-11. Published L70 hours limited to 6 times actual LED test hours

Ambient Temperature °C	Driver mA	Calculated L70 Hours	L70 per TM-21	Lumen Maintenance % at 60,000 hrs
25°C	up to 1050 mA	>100,000 hours	>60,000 hours	>96%

Specifications

Housing

Made of low copper die cast A360 Aluminum alloy, for a high resistance to corrosion, 0.100" (2.5mm) minimum thickness. Fits on a 1.66" (42mm) O.D. (1.25" NPS), 1.9" (48mm) O.D. (1.5" NPS) or 2 3/8" (60mm) O.D. (2" NPS) by 5 1/4" (133mm) minimum long tenon. Comes with a zinc plated clamp fixed by 2 zinc plated hexagonal bolts 3/8 16 UNC for ease of installation. Provides an easy step adjustment of +/- 5° tilt in 2.5° increments. A quick release, tool less entry, hinged, removable polymeric door with integral latch opens downward to provide access to electronic components and to a terminal block. Door is secured to prevent accidental dropping or disengagement. A clearance of 8" (203mm) at the rear is required in order to remove the door. Complete with a bird guard protecting against birds and similar intruders and an ANSI label to identify wattage and source (both included in box).

Light Engine

Composed of 4 main components: LED Module / Optical System / Heat Sink / Driver.

Electrical components are RoHS compliant, IP66 sealed light engine. LEDs tested by ISO 17025-2005 accredited lab in accordance with IESNA LM-80 guidelines in compliance with EPA ENERGY STAR, extrapolations in accordance with IESNA TM-21. Metal core board ensures greater heat transfer and longer lifespan.

LED Module: (Included), High performance white LEDs. Color temperature as per ANSI/NEMA, bin neutral white 4000 Kelvin nominal (3985 +/- 275K or 3710K to 4260K), CRI 70 Min.

Optical System: Composed of high performance UV stabilized optical grade polymer refractor lenses to achieve desired distribution optimized to get maximum spacing, target lumens and a superior lighting uniformity. System is rated IP66. Performance shall be tested per LM-63, LM-79 and TM-15 (IESNA) certifying its photometric performance. Dark Sky compliant with 0% uplight and U0 per IESNA TM-15.

Heat Sink: Built in the housing, designed to ensure high efficacy and superior cooling by natural vertical convection air flow pattern always close to LEDs and driver optimising their efficiency and life. Product does not use any cooling device with moving parts (only passive cooling). Wide openings enable natural cleaning and removal of dirt and debris. Entire luminaire is rated for operation in ambient temperature of -40°C / -40°F up to +40°C / +104°F.

Driver: High power factor of 95%. Electronic driver, operating range 50/60 Hz. Auto adjusting universal voltage input from 120 to 277 or 347 to 480 VAC (140W48LED4K available in 120-277V only) rated for both application line to line or line to neutral, Class I, THD of 20% max.

DMG: Dimming compatible 0-10 volts.

The current supplying the LEDs will be reduced by the driver if the driver experiences internal overheating as a protection to the LEDs and the electrical components. Output is protected from short circuits, voltage overload and current overload. Automatic recovery after correction. Standard built in driver surge protection of 2.5kV (min).

Integrated Features

DMG: Dimmable driver 0-10V.

RC: Receptacle for a twist-lock photocell or shorting cap. Use of photocell or shorting cap is required to ensure proper illumination.

SP1: Surge protection device tested in accordance with ANSI/IEEE C62.45 per ANSI/IEEE C62.41.2 Scenario I Category C High Exposure 10kV/10kA waveforms for Line-Ground, Line-Neutral and Neutral-Ground, and in accordance with DOE MSSLC Model Specification for LED Roadway Luminaires Appendix D Electrical Immunity High test level 10kV/10kA.

Please note that these integrated features always come with StreetView luminaire.

SVM StreetView

LED Cobra Head: 16, 32, and 48 LED

Specifications (continued)

Driver and Luminaire Options

AMPD*: Driver pre-programmed for compatibility with Amplight control system.

AST*: Pre-set driver for progressive start-up of the LED module(s) to optimize energy management and enhance visual comfort at start-up.

CLO*: Pre-set driver to manage the lumen depreciation by adjusting the power given to the LEDs offering the same lighting intensity during the entire lifespan of the LED module.

DALI*: Pre-set driver compatible with the DALI control system.

OTL*: Pre-set driver to signal end of life of the LED module(s) for better fixture management.

CDMG*: Dynadimmer standard dimming functionalities including pre-programmed scenarios to suit many applications and needs from safety to maximum energy savings.

Safety Mode:

CDMGS25: 4 hours, 25% power dimming

CDMGS50: 4 hours 50% power dimming

CDMGS75: 4 hours 75% power dimming

Median Mode:

CDMGM25: 6 hours 25% power dimming

CDMGM50: 6 hours 50% power dimming

CDMGM75: 6 hours 75% power dimming

Economy Mode:

CDMGE25: 8 hours 25% power dimming

CDMGE50: 8 hours 50% power dimming

CDMGE75: 8 hours 75% power dimming

* Not available with HVU (347-480V)

SP2: 20kV / 20kA surge protection device that provides extra protection beyond the SPI 10kV/10kA level.

HS: House side shield, 1 per 16 LED light engine.

PH8*: Twist-lock Photoelectric Cell, UNIV (120-277VAC).

PH8/347*: Twist-lock Photoelectric Cell, HVU (347VAC).

PH8/480*: Twist-lock Photoelectric Cell, HVU (480VAC).

PH8XL*: Twist-lock Photoelectric Cell, extended life, UNIV (120-277VAC).

PH9*: Shorting cap.

* Use of photoelectric cell or shorting cap is required to ensure proper illumination.

SPC: Starsense twist-lock photoelectric cell and antenna node, on / off.

Luminaire Useful Life

Refer to IES files for energy consumption and delivered lumens for each option. Based on ISTMT in situ thermal testing in accordance with UL1598 and UL8750, Philips System Reliability Tool, Philips Advance data and Philips Lumileds LM-80/TM-21 data, expected to reach 100,000 + hours with >L70 lumen maintenance @ 25°C. Luminaire Useful Life accounts for LED lumen maintenance AND all of these additional factors including: LED life, driver life, PCB substrate, solder joints, on/off cycles, burning hours and corrosion.

Wiring

The connection of the luminaire is done using a terminal block connector 600V, 85A for use with #2 to #14 AWG. wires from the primary circuit, located inside the housing. Due to the inrush current that occurs with electronic drivers, recommend using a 10Amp time-delay fuse to avoid unwanted fuse blowing (false tripping) that can occur with normal or fast acting fuses.

Hardware

All exposed screws shall be complete with Ceramic primer seal to reduce seizing of the parts, also offers a high resistance to corrosion. All seals and sealing devices are made and/or lined with EPDM and/or silicone and/or rubber.

Finish

Color in accordance with the AAMA 2603 standard. Application of polyester powder coat paint (4 mils/100 microns) with ± 1 mils/24 microns of tolerance. The Thermosetting resins provides a discoloration resistant finish in accordance with the ASTM D2244 standard, as well as luster retention in keeping with the ASTM D523 standard and humidity proof in accordance with the ASTM D2247 standard.

The surface treatment achieves a minimum of 2000 hours for salt spray resistant finish in accordance with testing performed and per ASTM B117 standard.

LED products manufacturing standard

The electronic components sensitive to electrostatic discharge (ESD) such as light emitting diodes (LEDs) are assembled in compliance with IEC61340-5-1 and ANSI/ESD S20.20 standards so as to eliminate ESD events that could decrease the useful life of the product.

Vibration Resistance

The SVM meets the ANSI C136.31, American National Standard for Roadway Luminaire Vibration specifications for Bridge/overpass applications. (Tested for 3G over 100,000 cycles by independent lab)

Certifications and Compliance

cULus Listed for Canada and USA. Luminaire meets DOE and MSSLC Model Specification for LED Roadway Luminaires. StreetView LED Cobrahead luminaires are DesignLights Consortium qualified. Luminaire complies with or exceeds the following ANSI C136 standards: .2, .3, .10, .14, .15, .22, .25, .31, .37, .41.

Limited Warranty

10-year limited warranty.

See philips.com/warranties for details and restrictions.

Brackets/Arms

For brackets / arms available with this luminaire, see Lumec 3D for details.

